

# Tailor-made Solutions for the Glass Industry

Effective | Robust | Reliable



[www.rath-group.com/  
glass](http://www.rath-group.com/glass)

OUTSTANDING INSIDE  
Refractory Solutions

**RATH**

# OUTSTANDING SOLUTIONS PERFECTLY DESIGNED

RATH combines tradition and innovation in a unique way. Our extensive product portfolio is made in-house at our facilities. By using selected materials and precise processing techniques, we guarantee the highest quality. This results in perfectly suitable refractory solutions for a wide variety of applications in furnace and forehearth construction.

## **COMPLETE REFRACTORY SOLUTIONS WITH AN OPTIMAL PRICE-PERFORMANCE RATIO**

Our extensive product range is manufactured in-house. The RATH sales teams are focused on the sector and familiar with its specific requirements. In addition to this, our technical departments possess the required expertise in engineering and assembly. This means we can offer our customers individual, complete refractory solutions with an optimal price-performance ratio.

## **EFFICIENT PRODUCTION: A CRYSTAL-CLEAR GOAL.**

The window letting in the light, the wine bottle preserving the bouquet, the mirror that “examines” us every day – glass is a key element of our daily lives. Great expertise is needed to produce it and the energy costs are high. The quality of the refractory material is a key factor, both technical and economic in this complex process. RATH offers a wide range of refractory and insulating products for all types of glass melting furnaces, melting tanks, regenerative U-flame furnaces, cross fired furnaces, recuperative furnaces, oxy-fuel, electric furnaces, daily tanks, pot furnaces, as well as provides complete refractory solutions for different types of forehearth systems.



Feeder burner blocks



### **CUSTOMIZED SOLUTIONS ARE OUR SPECIALTY**

If you rely on RATH, you opt for products that are qualitatively and technologically up to date. RATH offers the right refractory and insulating materials for the construction and operation of all types of furnaces and associated units from the various areas of glass production:



Our product range extends from dense refractory bricks and cast components to refractory, insulating and gunning castables, insulating bricks and other insulation materials such as high temperature insulation wool, vacuum-formed products and micro porous products.

# GLASS-MAKING IS SIMPLY A HOT TOPIC ...



More than 130 years of experience in refractory technology have made one thing crystal clear: We are at home wherever heat-resistant materials are essential.

This naturally also applies to the glass industry, for which we have developed a comprehensive range of refractory and heat-insulating products during the past 20 years.

## TWO TECHNOLOGY LEADERS - ONE SOLUTION PROVIDER

Including the original Emhart Glass System, RATH offers you the complete range of highest quality refractory materials for the entire glass making process.

All former Emhart refractories are now produced by RATH. Covering your complete process chain for high glass results, we deliver refractory and insulating materials for regenerator chambers, furnaces, distributors, forehearth, and the original Emhart Glass System for feeder expendables.

## A CRYSTAL-CLEAR GOAL: QUALITY

### EXPERTISE

For perfect glass processing with crystal-clear results, only high-purity raw materials are permitted for the refractory parts when it comes to purchasing and quality assurance at RATH. From melting tanks to feeder expendables, our application engineers ensure that every single component is absolutely true to size and meets the chemical and thermal requirements. The purity and the surface quality of the components, in particular, are top priorities for our refractory experts and are ensured in the RATH laboratories by our certified staff.

### COMPLETE RANGE

Our products have been developed to withstand the highest temperatures, as well as chemical and mechanical loads. As a system supplier, RATH offers a comprehensive range of sintered alumina and zircon products, as well as all kinds of thermal insulation products. Our products are suitable for all types of glass melting furnaces, melting tanks, regenerators and distributors. In the forehearth systems, we can offer you complete refractory solutions from channel blocks, up to the roof and bournner course, superstructure and substructure insulation.

### ADVICE

Our highly qualified experts, engineers and technicians for industrial glass applications have the necessary expertise to develop the most powerful refractory materials - tailored to your individual requirements .

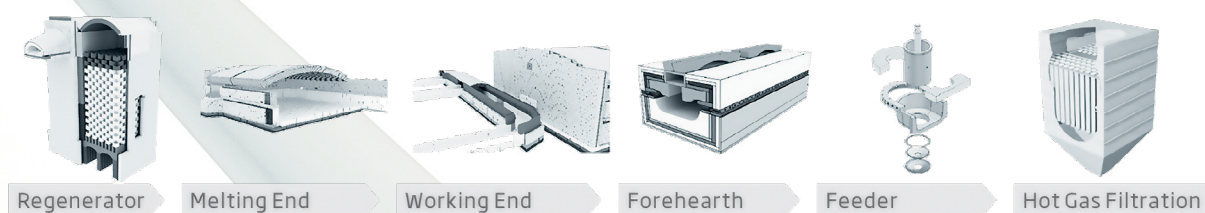

# A KALEIDOSCOPE OF REFRACTORY PRODUCTS, INCLUDING YOURS



HIGH-TEMPERATURE INSULATION WOOL<sup>1</sup>

Name	CALSITRA Mat 1100	CALSITRA Mat 1250	ALSITRA Mat 1300	ALSITRA Mat 1400	ALSITRA Mat 1400 Z	ALTRA® Mat 72	
Raw material base	Calcium silicate	Calcium/Magnesium silicate	Aluminium silicate	Aluminium silicate	Alumina- zircon-silicate	Aluminium silicate	
Classification temperature [°C]	1100	1250	1300	1400	1400	1650	
Continuous application temperature [°C]	900	1100	<1150	<1250	<1300	1600	
Average fiber diameter [µm]	2 - 4	2 - 4	1.5 - 3.5	1.5 - 3.5	2 - 3	2 - 4	
Fiber density [kg/m³]	96 -128	96 -128	96 -160	96 -160	96 -128	60-120	
Permanent linear change (after 24 hours at:)	1100°C	-2.0	-	-2	-	-1	-
	1200°C	-	-	-3	-2	-1.6	-
	1300°C	-	1250°C/-3.0	-4	-3	-3.2	-
	1400°C	-	-	-	-4	-4	-
	1500°C	-	-	-	-	-	-1
	1600°C	-	-	-	-	-	-2.0//1650°C/-4.0
Chemical analysis fired [%]	Al <sub>2</sub> O <sub>3</sub>	-	-	48	54	37	72
	SiO <sub>2</sub>	62-68	70-80	52	46	48	28
	CaO/MgO	26-32	18-25	-	-	-	-
	ZrO <sub>2</sub>	-	-	-	-	15	-
Thermal conductivity [W/mK] (hot wire method)	400°C	0.11	-	0.11	0.11	0.08	0.09
	600°C	0.15	0.14	0.15	0.15	0.12	0.13
	800°C	0.23	0.23	0.21	0.21	0.18	0.19
	1000°C	0.31	0.34	0.31	0.31	0.20	0.28
	1200°C	-	0.48	0.44	0.44	0.36	0.41
	1400°C	-	-	0.64	0.64	-	0.61

<sup>1</sup> this table only presents a part of the wide Rath product range

# A FLEXIBLE COMPANY FOR SPECIAL REQUIREMENTS

*WE IMPLEMENT YOUR IDEAS PERFECTLY.*

Optimized structures and production processes enable the Rath Group to always react flexibly to customer requirements, whether in terms of production deadlines, single pieces or special applications. Our customer service departments can thus satisfy any request - and always with the focus on uncompromising quality.

Mullite bottom layer, Oxy-fuel glass melting furnace



Melting tank fireclay bottom

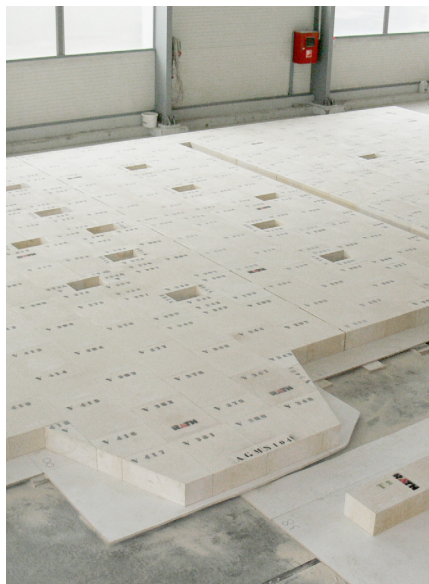

Melting tank bottom with big size light-weight insulation blocks





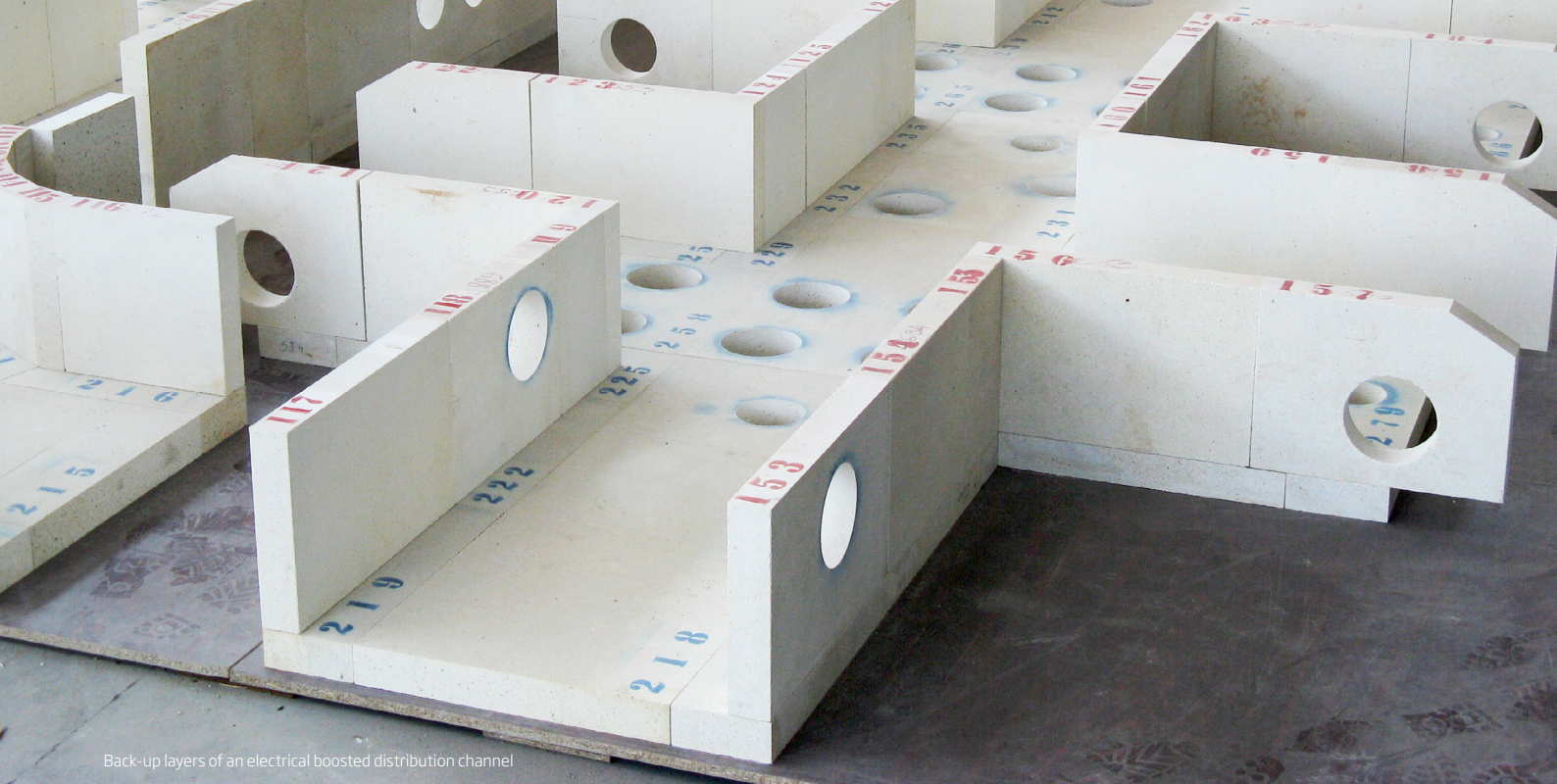

Back-up layers of an electrical boosted distribution channel

## INSULATING FIRE BRICKS<sup>1</sup>

Name	PORRATH® 900	PORRATH® FL 24-06	PORRATH® FL 24-10	PORRATH® FL 25-08	PORRATH® FL 25-10	PORRATH® FL 25-12	PORRATH® FL 26-08	PORRATH® FL 27-12	PORRATH® FL 28-09	PORRATH® FL 30-11	
Raw material base	Calcium-Alumina-Silicate	Aluminium silicate	Aluminium silicate	Aluminium silicate	Aluminium silicate	Aluminium silicate	Aluminium silicate	High alumina fireclay	Aluminium silicate	Aluminium silicate	
Classification temperature [°C]	900	1350	1350	1380	1400	1400	1430	1500	1540	1650	
ASTM-Group	-	-	-	-	-	-	26	-	28	30	
Bulk density [g/cm <sup>3</sup> ]	0.45	0.64	1	0.8	1	1.15	0.8	1.2	0.9	1.1	
Cold crushing strength [MPa]	1	1.2	8	4	8	8	3.5	15	4	5	
Permanent linear change [%]	875°C/24h	1320°C/12h	1320°C/12h	1350°C/12h	1370°C/12h	1370°C/12h	1400°C/12h	1500°C/12h	1510°C/12h	1620°C/12h	
	-0.3	-0.7	-1	-0.9	-0.9	-0.5	-0.5	-1.4	-0.7	-1.1	
Chemical analysis [%]	Al <sub>2</sub> O <sub>3</sub>	15	37	39	38	40	48	52	64	66	72
	SiO <sub>2</sub>	60	56	55	55	54	47	44	31	31	27
	Fe <sub>2</sub> O <sub>3</sub>	4	1.9	1.9	2.2	2.3	1.8	1.1	1.3	0.8	0.3
Thermal conductivity [W/mK] (hot wire method)	200°C	0.12	-	-	-	-	-	-	-	-	-
	400°C	0.14	-	-	-	-	-	-	-	-	-
	600°C	0.17	0.28	0.39	0.36	0.42	0.46	0.36	0.52	0.38	0.44
	800°C	0.20	0.32	0.44	0.41	0.46	0.50	0.39	0.57	0.40	0.46
	1000°C	-	0.38	0.49	0.47	0.50	0.55	0.43	0.63	0.43	0.51
	1200°C	-	0.43	0.54	0.50	0.54	0.60	0.48	0.69	0.47	0.58
	1400°C	-	-	-	-	-	-	0.53	0.77	0.50	0.61

<sup>1</sup> this table only presents a part of the wide Rath product range

# REFRACTORY SOLUTIONS IN ALL SHAPES AND FORMS

## *ALL PRODUCTS FROM ONE SINGLE SOURCE.*

Our extensive product portfolio enables us to cover virtually all product requirements for regenerative glass melting furnaces. The range extends from regenerator walls for low-, medium- or high-temperature zones through regenerator crowns to complete insulation of waste gas channel. Rath offers an optimal selection of high-quality products. Whether

- › low-iron oxide fireclay bricks, castables and pre-casted blocks
- › andalusite bricks, andalusite-mullite bricks, mullite bricks
- › insulating fire bricks
- › calcium-silicate boards
- › or finishing mixes

## *INSULATING FIRE BRICKS, ENDLESS VERSATILITY.*

Insulating fire bricks are available at densities from 0.45 to 1.4 g/cm<sup>3</sup> and classification temperatures from 900°C up to 1840°C. Large calibre bottom layer blocks are also available, as are tailor-made designs for special applications.

Regenerator chamber



Doghouse protection arch



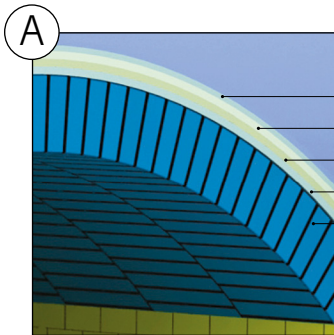
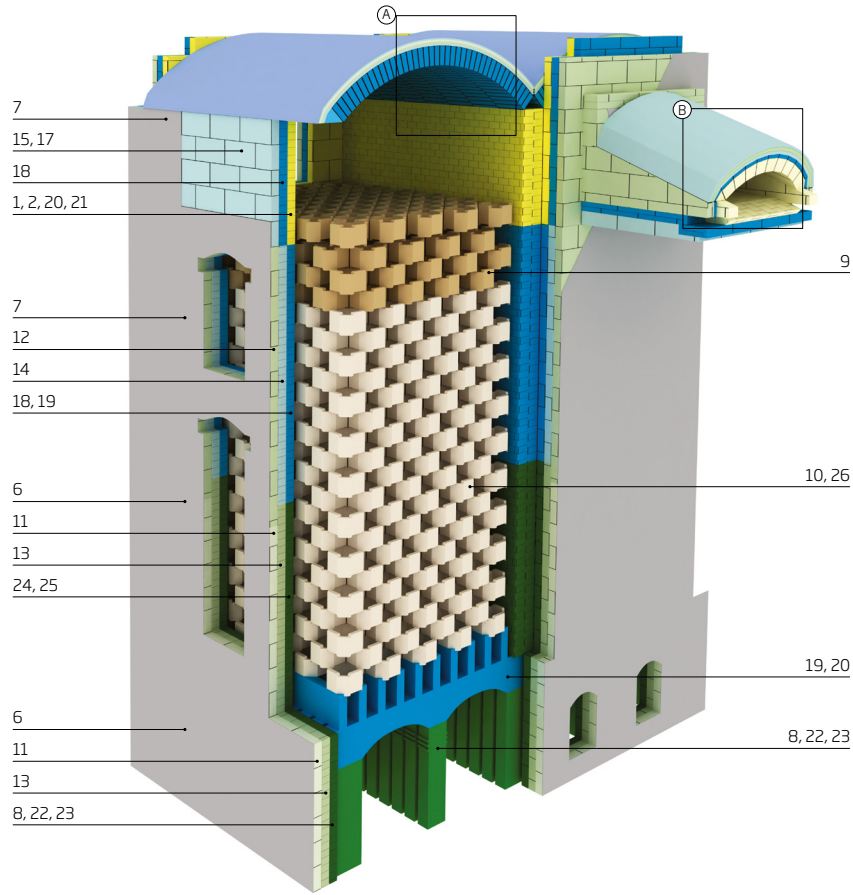

3  
4, 5  
16  
17  
1, 2, 19, 20, 21

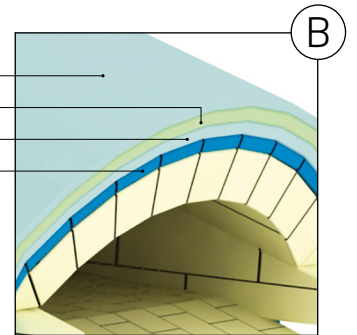

4, 5  
16  
17  
18

KEY

Alurath E 75	1	Durrath HD 48	8	Porrath FL 25-10	15	Suprath A 40-t	22
Alurath M 704	2	Korrath K 99E	9	Porrath FL 26-08	16	Suprath A 401-t	23
Calsitra MS 1250	3	Magnesite	10	Porrath FL 28-09	17	Suprath A 403-t	24
Carath FL 1301	4	Porrath 900	11	Silrath AK 60	18	Suprath T 45	25
Carath FL 1404	5	Porrath FL 24-06	12	Silrath AK 65	19	Zircon-magnesite	26
CAS 1000	6	Porrath FL 24-10	13	Silrath AK 70	20		
CAS 1100	7	Porrath FL 25-08	14	Silrath AK 75M	21		

# THE CORE OF YOUR PRODUCTION PERFECTLY LINED

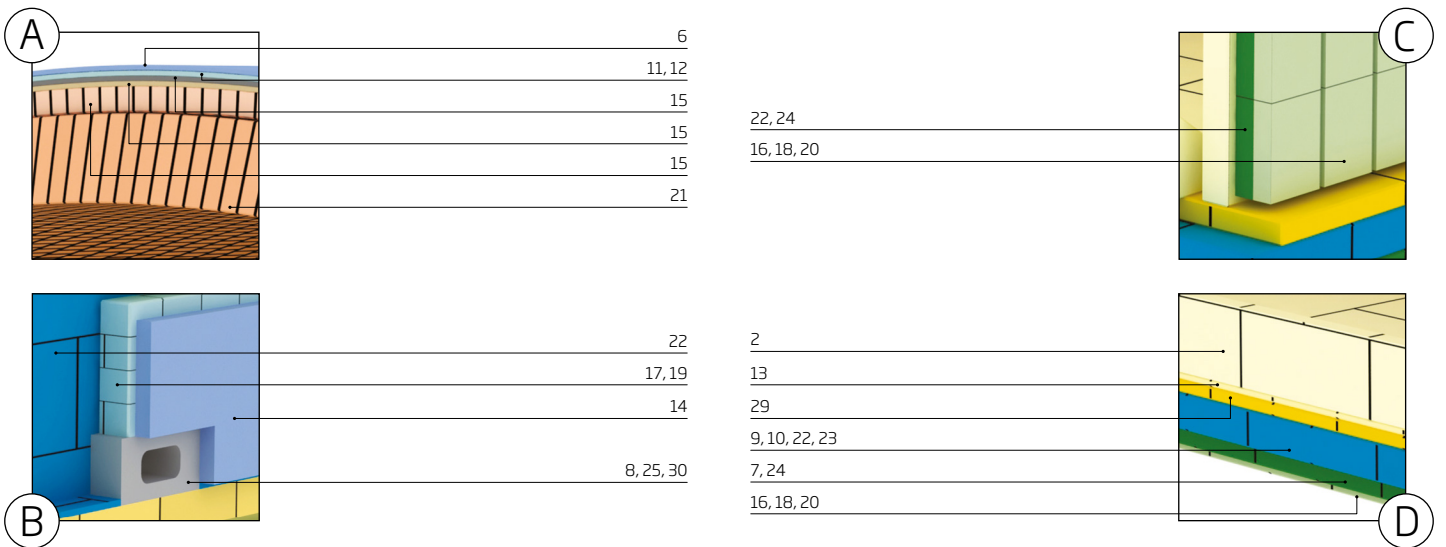
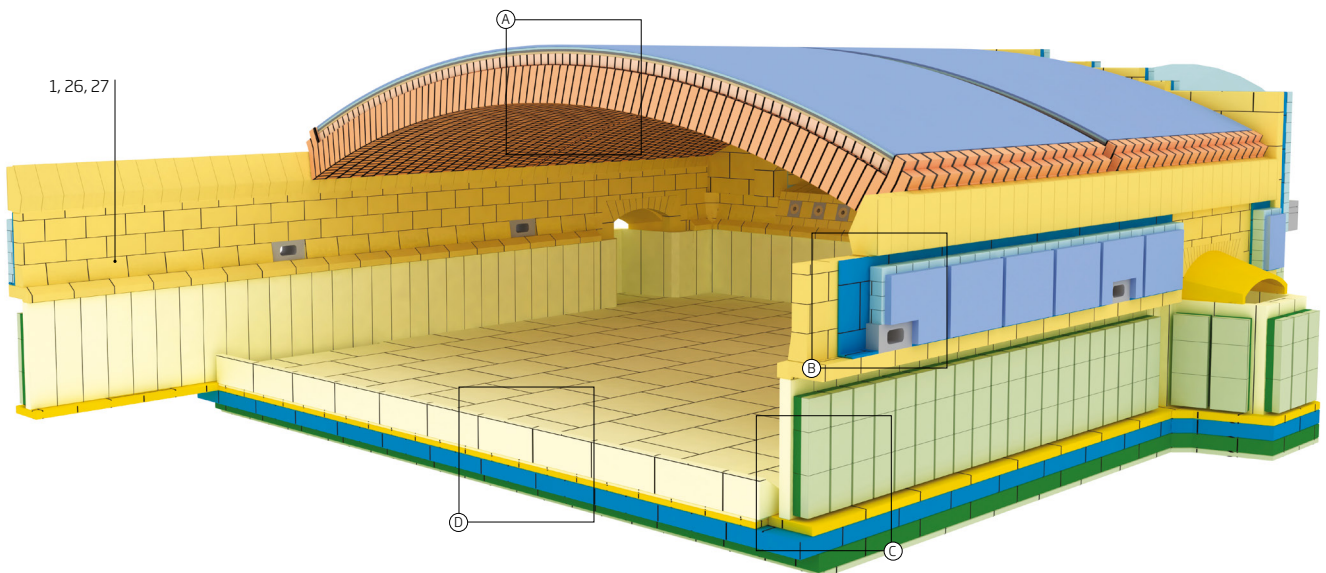

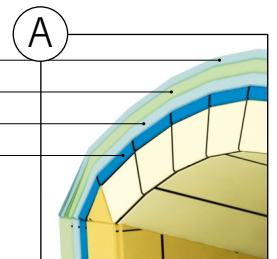
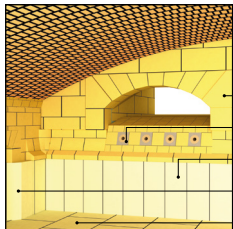
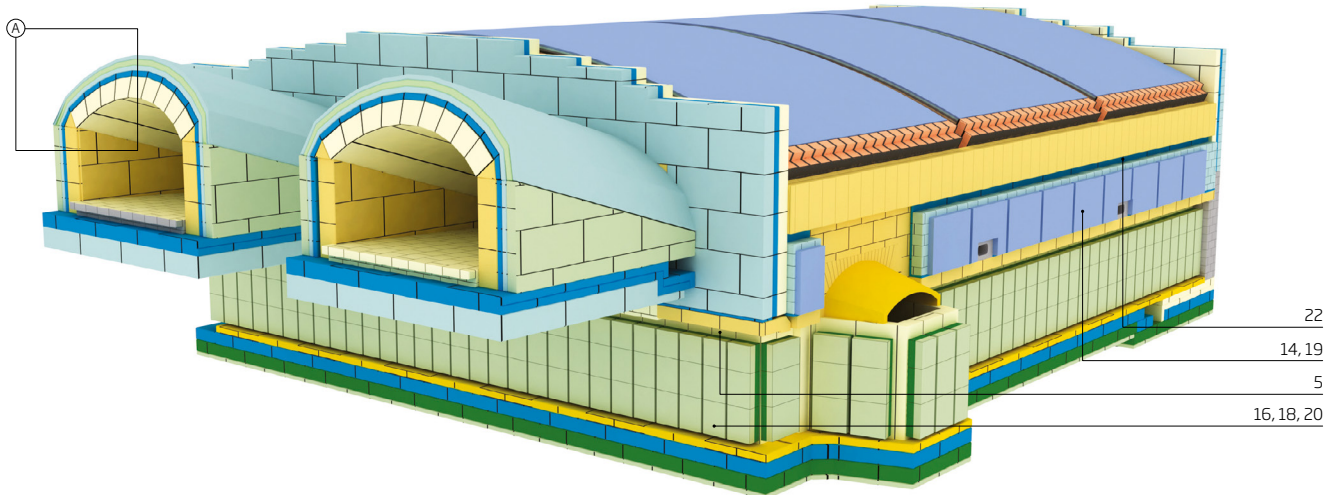

## KEY

Alurath E 75	1	Carath FL-1301	11	Silica	21
AZS Fused-cast	2	Carath FL-1404	12	Silrath AK 60	22
AZS (33%)	3	Carathplast 1650-AZS	13	Silrath AK 601	23
AZS (33-41%)	4	Evac EVS 131	14	Suprath A 40-t	24
AZS (41%)	5	LW Silica	15	Vibrorath A 70M	25
Calsitra MS 1250	6	Porrath FL 25-12	16	Zirrach AZS 20	26
Carath 1400-LC	7	Porrath FL 26-08	17	Zirrach AZS 30	27
Carath 1650-ULC AZS	8	Porrath FL 27-12	18	Zirrach AZS 20NC-SF	28
Carath 1650 LC-SF	9	Porrath FL 28-09	19	Zirrach ZS 65	29
Carath 1655-LC	10	Porrath FL 24-16	20	Zirrach ZS 65 NCSF	30

# QUALITY AND LIFETIME - THE IDEAL COMBINATION



Melting tank burner block

## *OUR QUALITY ENSURES A LONG "LIFETIME".*

For melting tank linings we offer:

- › pressed or
- › casted

big size bottom layer blocks that have been grinded and pre-assembled according to the customer's requirements. In addition we offer special shape blocks, such as burner blocks, peephole blocks, camera blocks, bricks for doghouse protection arches, melting tank hanging roof and many other products with high fire resistance. Concerning raw material composition, for our bricks we use our wide range of fireclay, andalusite or zircon raw material. Our monolithics are mostly made of fireclay, andalusite, zircon and zircon-mullite.

Doghouse of melting tank



Melting tank superstructure/detail of peephole block

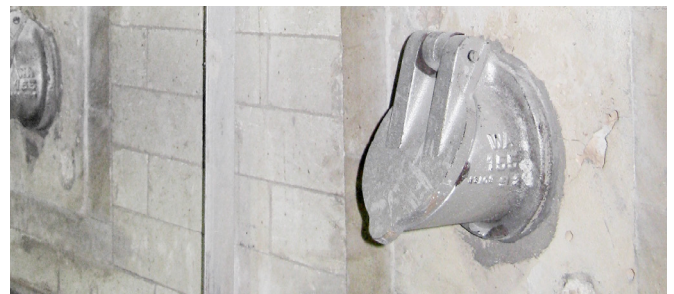

Melting tank

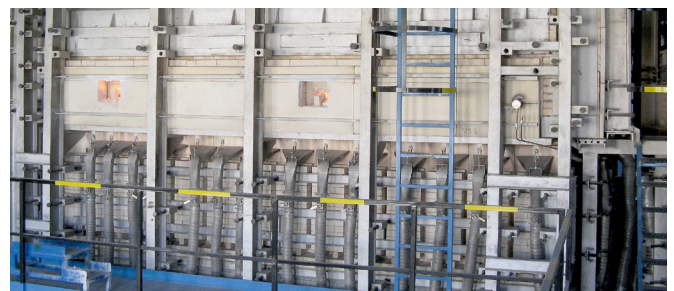

DENSE BRICKS<sup>1</sup>

Name		SUPRATH A 40-t	SUPRATH T 45	DURRATH HD 48	SILRATH AK 601	SILRATH AK 60	SILRATH AK 65	KORRATH K 702 Cr	ALURATH E 75	KORRATH K 974 Zr	KORRATH K 99
Raw material base		Fireclay	Mullite contained fireclay	Low-iron mullite fireclay	Andalusite	Andalusite	Andalusite	Corundum, Escolaitite	Fused mullite	Corundum	Tabular alumina
Bulk density [g/cm <sup>3</sup> ]		2.25	2.30	2.50	2.55	2.58	2.65	3.56	2.69	3.40	3.15
Open porosity [%]		16	15	8	14	14	13	15	13	14	17
Cold crushing strength [MPa]		50	60	120	70	100	110	150	180	130	80
Thermal shock resistance [number of quenching]		30	30	35	50	100	120	4	40	36	10
Refractoriness under load T <sub>0.5</sub> [20 MPa]		1420°C	1400°C	1620°C	1560°C	1600°C	>1600°C	>1600°C	>1700°C	>1600°C	>1600°C
Chemical analysis [%]	Al <sub>2</sub> O <sub>3</sub>	40	43	49	58	60	62	69	73	97	99
	SiO <sub>2</sub>	50	-	48	39	37	33	-	26	0.10	0.20
	Fe <sub>2</sub> O <sub>3</sub>	1.9	2	1.4	1.20	1	1	0.20	0.3	0.10	0.10
	Cr <sub>2</sub> O <sub>3</sub>	-	-	-	-	-	-	28	-	-	-
	ZrO <sub>2</sub>	-	-	-	-	-	-	2.90	-	2.80	-
Hot modulus of rupture [MPa]	1200°C	-	-	-	-	-	-	21.0	20	12.0	18.0
	1400°C	1.8	1.9	-	-	2.5	2.0	23.0	6.0	8.0	12.0
	1500°C	-	-	-	-	-	-	23.0	5.0	6.0	8.5
Thermal conductivity [W/mK] (hot wire method)	800°C	-	1.50	-	1.64	2.02	1.75	-	-	2.40	2.90
	1000°C	-	1.60	-	1.81	2.12	1.98	2.40	3.0	2.50	2.90
	1200°C	-	1.80	-	1.99	2.32	2.24	2.50	3.40	2.60	3.00
	1400°C	-	2.00	-	2.17	2.64	2.53	2.60	3.80	2.70	-

<sup>1</sup> this table only presents a part of the wide Rath product range

# LAY THE GROUNDWORK FOR A SMOOTH PROCESS

## YOUR INVESTMENT PAYS OFF IN THE LONG TERM.

Whether we develop products, select materials or plan your system, we always focus on quality and functionality, as the basis for your long-term production to run smoothly. Economically, an investment that pays for you. We can build your furnace largely from one single source. We provide solutions for the various layers of the substructure.

The superstructure will be made of cover blocks (forehearths, working end) or with end arches (working end), as requested. Here we pre-assemble parts of the system - reducing on-site construction time and improving quality. Your investment pays off in the long term.

### UNFORMED NO-CEMENT SHAPES

Name	Vibrorath A 70	
Raw material base	Andalusite/Corundum	
Service temperature [°C]	1700	
Bulk density [g/cm³]	2.43	
Open Porosity [Vol.-%]	≤20	
Cold crushing strength [MPa]	≥55	
Chemical analysis [%]	Al <sub>2</sub> O <sub>3</sub>	68
	SiO <sub>2</sub>	30
	Fe <sub>2</sub> O <sub>3</sub>	0.6

Distribution channel/forehearth superstructure insulation, with detail of flue openings



Working end insulating bottom layers

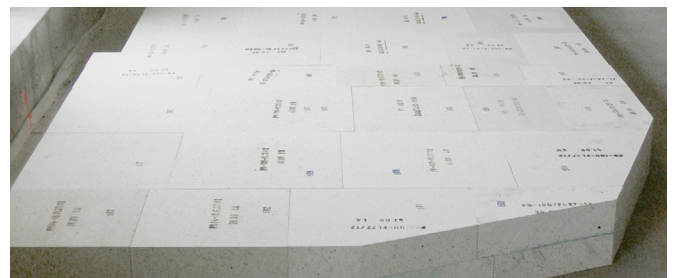

Forehearth channel



Pre-assembled forehearth cover blocks





1, 15, 16  
12  
4, 9, 10

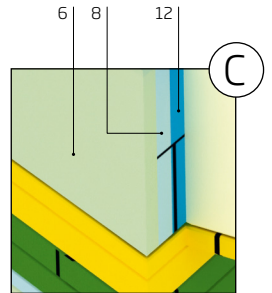
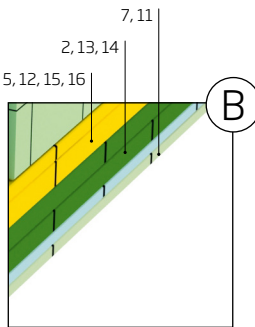
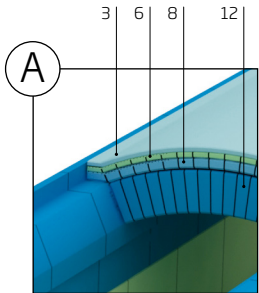
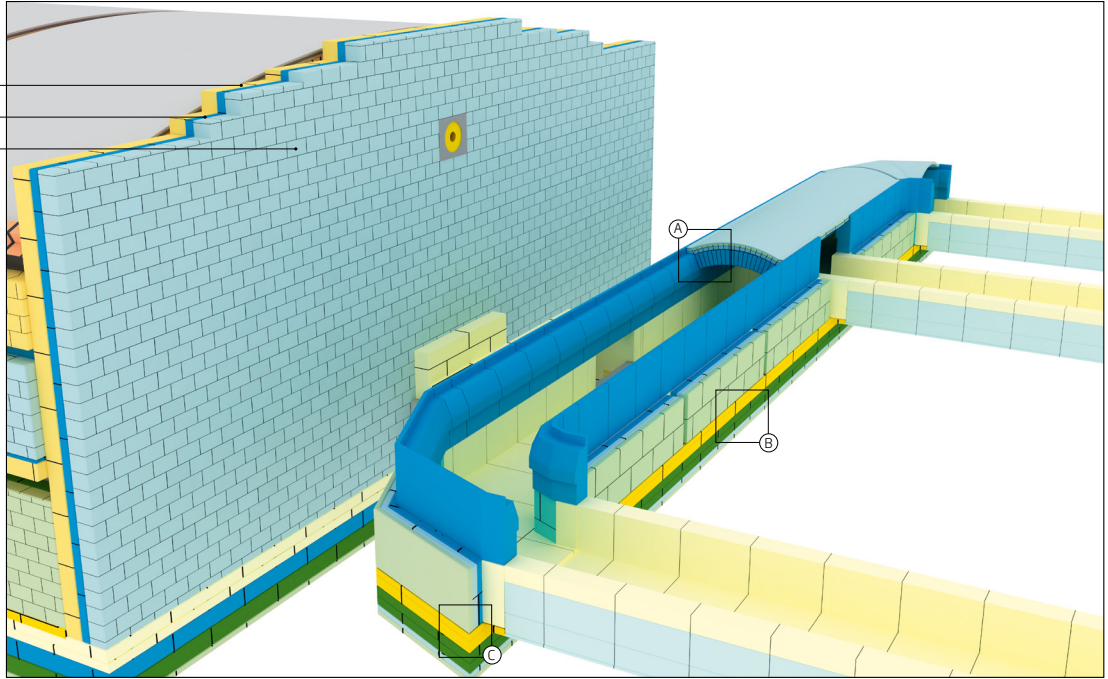

KEY

Alurath E 75	1	Porrath FL 28-09	9
Carath 1400 LC	2	Porrath FL 30-11	10
Carath FL-1301	3	Porrath FL 24-16	11
EVAC EVS 131	4	Silrath AK 60	12
Korrath K 901	5	Suprath A 40-t	13
Porrath FL 24-06	6	Suprath A 401-t	14
Porrath FL 25-12	7	Zirath AZS 20	15
Porrath FL 25-08	8	Zirath AZS 30	16

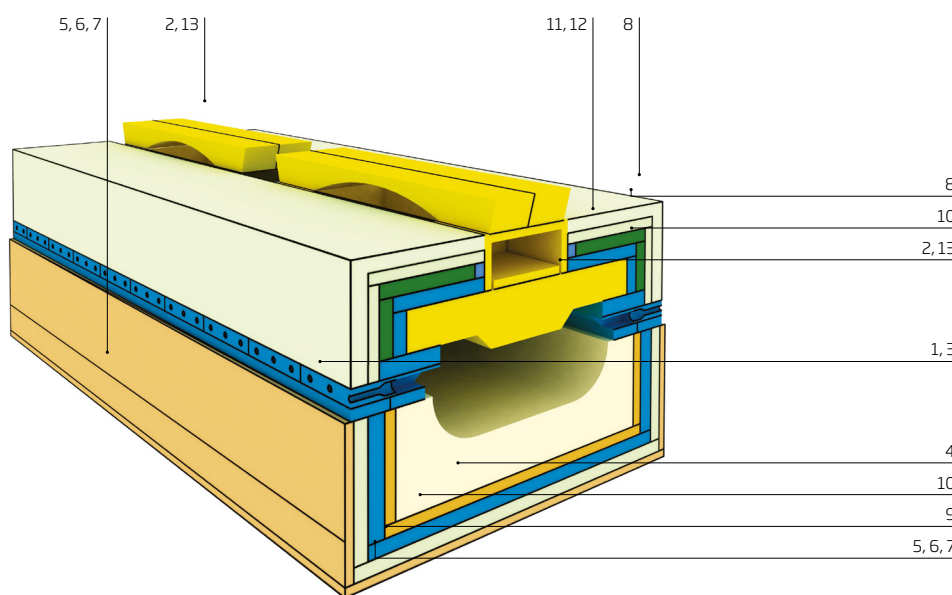

— KEY —

Carath 1650-LCSF	1
Carath 1650-ULC AZS	2
Carath 1655-LC	3
Carathplast 1650 AZS	4
CAS 1000	5
EVAC EVS 131	6
Kerform KVS 121	7
Porrath FL 24-06	8
Porrath FL 25-10	9
Silrath AK 601	10
Suprath A 40-t	11
Suprath A 401-t	12
Vibrorath A 70M	13

UNSHAPED REFRACTORIES/PRECAST SHAPES<sup>1</sup>

	<i>dense castable</i>	<i>low cement castables</i>			<i>ultra-low cement castables</i>		<i>insulating castables</i>		
Name	CARATH 1400-D	CARATH 1400-LC	CARATH 1500-LC	CARATH 1655-LC	CARATH 1651-ULC	CARATH 1650-ULC AZS	CARATH FL-1401	CARATH FL-1405	
Raw material base	fireclay	high mullite fireclay	high mullite fireclay	andalusite	spinel	Zircon mullite	light weight fireclay	light weight fireclay	
Service temperature [°C]	1400	1400	1500	1650	1650	1650	1400	1400	
Material requirement [kg/m <sup>3</sup> ]	2250	2300	2350	2550	2850	3000	1400	1500	
Cold crushing strength [MPa] <i>(after drying at 110 °C)</i>	40	100	100	75	100	110	25	25	
Grain size [mm]	<5, <10	<10	<10	<6	<6	<6	<8	<8	
Chemical analysis [%]	Al <sub>2</sub> O <sub>3</sub>	46	50	52	63	85	56	45	55
	SiO <sub>2</sub>	40	41	42	34	2.4	16	35	30
	Fe <sub>2</sub> O <sub>3</sub>	<1.5	1.3	1	0.8	-	-	3	0.8
	BaO	-	-	-	-	-	-	-	-
	CaO	-	-	-	-	-	-	11	-
	MgO	-	-	-	-	10	-	-	-
	ZrO <sub>2</sub>	-	-	-	-	-	26	-	-
Thermal conductivity [W/mK] <i>(hot wire method)</i>	200 °C	1.29	1.27	-	-	2.90	2.30	-	0.53
	400 °C	1.25	1.29	-	-	2.60	2.27	-	0.53
	600 °C	1.22	1.34	-	-	2.30	2.23	-	0.55
	800 °C	1.21	1.41	-	1.73	2.10	2.18	0.55	0.60
	1000 °C	1.27	1.50	-	1.80	1.90	2.14	0.58	0.67
	1200 °C	1.42	1.62	-	2.01	1.80	2.09	0.63	0.77
	1400 °C	1.54	1.76	-	2.23	1.70	2.02	0.68	0.89

<sup>1</sup> this table only presents a part of the wide Rath product range

# ENTIRELY FROM ONE SOURCE. EVERYTHING FITS



Rath can supply its customers with complete forehearths thanks to its extensive product portfolio. This includes zircon-mullite or high alumina forehearth components and construction with forehearth safety and insulating layers (zircon-mullite, sillimanite or mullite).

The channel cover blocks are machined and pre-assembled. Produced in one of the newest and most modern components precast lines: partially automated with vibration technology. Adherence to the strictest possible quality criteria goes without saying.

Spout area (burner and cover blocks)



Gob forming

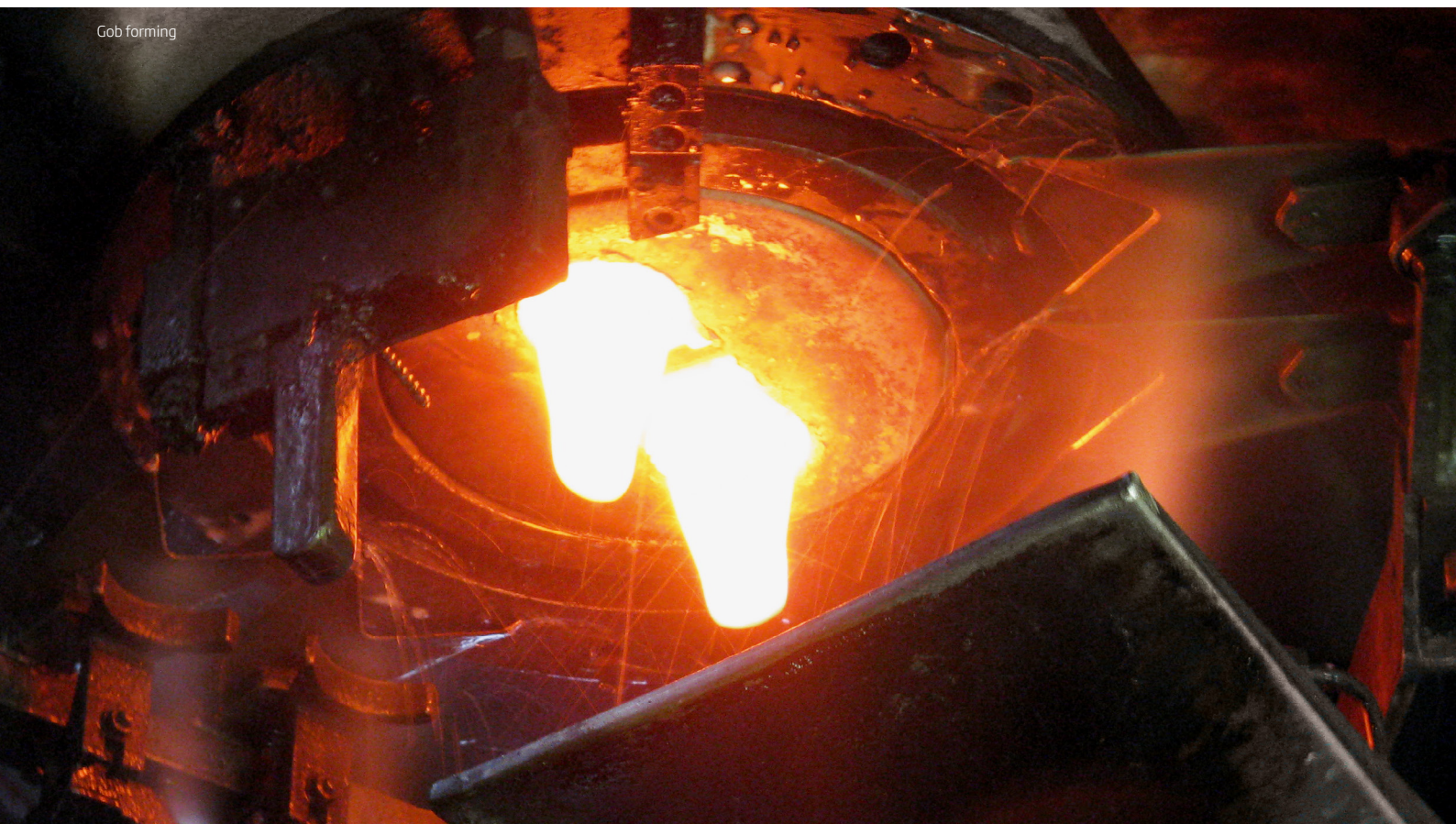

INSULATING MATERIALS<sup>1</sup>

		Vacuum formed shapes					
Name		EVAC EVF 131/180	EVAC EVS 131	EVAC EVS 144/ 400	EVAC EVS 151/700	KERFORM KVF 121	
Raw material base		Alkaline-earth silica wool	Alkaline-earth silicate wool with refractory fillers	Alkaline-earth silica wool	Alkaline-earth silica wool	Aluminium silicate wool	
Classification temperature [°C]		1300	-	-	-	-	
Maximum application [°C]		1300	1280	1450	1600	1250	
Continous application [°C]		-	-	1350	1500	1150	
Bulk density [kg/m³]		180	320	400	700	>160	
Permanent linear change [%]	900°C/24h	-	-	-	-	-1.0	
	1000°C/24h	-	-1.8	-	-	-2.0	
	1100°C/24h	-2.0	-3.0	-	-	-3.0	
	1150°C/24h	-	-	-	-	-	
	1200°C/24h	1250°C/-2.6	-	-	-	-	
	1300°C/24h	-3.7	-3.9	1450°C/-3.5	-	-	
	1400°C/24h	-	-	-	1450°C/-2.88	-	
	1500°C/24h	-	-	-	-2.85	-	
Chemical analysis [%]	SiO <sub>2</sub>	79	76	85	63	53	
	Al <sub>2</sub> O <sub>3</sub>	2.5	2	<1	3	46	
	BaO	-	-	-	-	-	
	MgO	19	-	14	6	-	
	CaO/MgO	-	22	-	-	-	
	CaO	-	-	-	-	-	
	ZrO <sub>2</sub>	-	-	-	29	-	
	organic components	6	5	-	-	5	
Thermal conductivity [W/mK] <i>(hot wire method)</i>	200°C	0.10	0.09	-	-	-	
	400°C	0.12	0.12	-	-	-	
	600°C	0.15	0.16	0.15	0.17	0.12	
	800°C	0.23	0.21	0.20	0.22	0.18	
	1000°C	0.35	0.29	0.27	0.27	0.25	
	1200°C	0.54	0.37	0.34	0.34	0.35	
	1400°C	-	-	0.42	0.42	-	

<sup>1</sup> this table only presents a part of the wide Rath product range

Vacuum formed shapes						Insulating panel
	KERFORM KVS 121	KERFORM KVS 141	KERFORM KVS 146/301	KERFORM KVS 161	ALTRAFORM KVS 161/302	CAS1000
	Aluminium silicate wool	Aluminium silicate wool	Aluminium silicate wool	Aluminium silicate wool/Alu- mina wool	Alumina wool	Calcium silicate
	-	-	1430	1600	1600	1000
	1250	1400	1400	1600	1600	-
	1150	1300	1300	1500	1600	-
	300	300	500	300	300	245
	-	-	-	-	-	-
	-	-1.6	-1.5	-	-	-
	-2.9	-2.5	-2.0	-	-	-
	-3.1	-	-	-	-	-
	1250°C/-3.7	1250°C/-3.7	1250°C/-3.1	-	-	-
	-	-	-	-	-	-
	-	-	-	-2.0	-3.0	-
	-	-	-	-2.0	+/-0	-
	-	-	-	-3.0	1.0	-
	49	44	64	34	26	45
	50	55	30	65	74	-
	-	-	-	-	-	-
	-	-	-	-	-	-
	-	-	-	-	-	42
	-	-	6	-	-	-
	4	4	-	4	4	0.02/alkaline
	-	-	-	-	-	-
	-	-	-	0.17	0.11	0.10
	0.15	-	-	0.18	0.14	0.14
	0.19	0.19	-	0.20	0.18	0.17
	0.25	0.24	-	0.26	0.23	-
	0.34	0.31	-	0.34	0.28	-
	-	0.40	-	0.44	0.34	-

# INDUSTRIES AND APPLICATIONS



Forging furnace

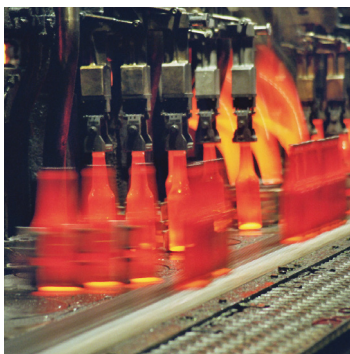

Glass production



Aluminum melting furnace

Thanks to their many projects, RATH employees have a great deal of experience and knowledge that they contribute to the development and planning of refractory linings.

## RATH HAS EXPERIENCE AND EXPERTISE IN SPECIFIC INDUSTRIAL APPLICATIONS

### Metal-processing industry

- Metallurgical heating furnaces
- Heat treatment furnaces
- Aluminum smelting furnaces
- Direct reduction plants
- Hot-gas filtration

### Petrochemistry, chemistry

- Carbon black reactors
- Reformers and cracking furnaces
- Chlorine reactors
- Sulfur extraction plants
- Hot-gas filtration

### Energy & environmental engineering

- Biomass firing systems
- Wood distillation, grate stoker furnaces
- Hot-gas generation
- Fluidized bed reactors
- Rotary kilns
- Waste incineration plants
- Heat exchangers
- Hot-gas filtration

### Tiled stoves and domestic fireplaces

- Complete oven systems
- Biological combustion chamber plus
- Flue systems
- Combustion chamber linings
- Inspection window doors
- Mortars and adhesives

### Ceramic industry

- Technical ceramics, sanitary ceramics, pottery ceramics, refractory ceramics
- Tunnel kilns
- Rotary furnaces
- Hood-type furnaces

### Special furnace construction

- Laboratory furnaces
- Dental furnaces
- Analytic devices

### Glass industry

- Regenerator chambers
- Melting ends
- Working ends
- Forehearths
- Basins for glass processing

# IN-HOUSE MANUFACTURING AT HIGHEST QUALITY LEVEL



Seven production sites in Europe and America are constantly exchanging information about manufacturing procedures to guarantee best products.

Quality at RATH is not just a buzz-word but a vivid corporate culture. Each individual employee strives for the best solution and does not give up until it is achieved.

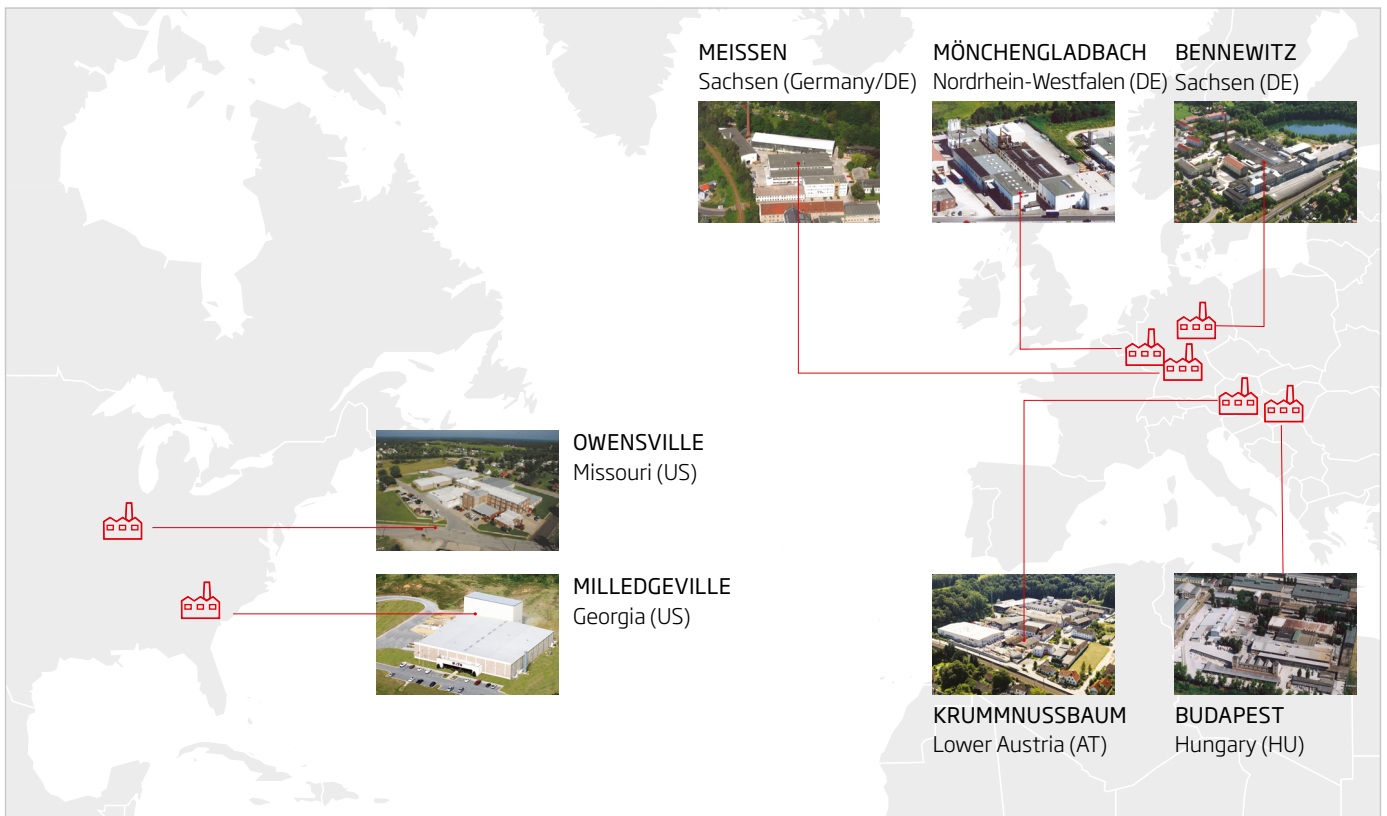

# RATH GROUP

## Our Sales Offices

### AUSTRIA

#### **RATH AG**

**Walfischgasse 14**

**A-1015 Vienna**

T: +43 (1) 513 44 27-0

F: +43 (1) 513 44 27-2187

#### **RATH BUSINESS SERVICE GMBH**

**Walfischgasse 14**

**A-1015 Vienna**

T: +43 (1) 513 44 27-0

#### **AUG. RATH JUN. GMBH**

**Hafnerstrasse 3**

**A-3375 Krummussbaum**

T: +43 (2757) 2401-0

F: +43 (2757) 2401-2286

### GERMANY

#### **Rath Sales GmbH & Co KG**

**Ossietzkystraße 37/38**

**D-01662 Meissen**

T: +49 (3521) 46 45 41-0

F: +49 (3521) 46 45 41-86

#### **Krefelder Strasse 680/682**

**D-41066 Mönchengladbach**

T: +49 (2161) 96 92 42-0

F: +49 (2161) 96 92 42-61

#### **Leulitzer Strasse 6D**

**D-04828 Bennewitz**

T: +49 (3425) 89 48 43-0

F: +49 (3425) 89 48-4313

### USA

#### **RATH INC.**

**290 Industrial Park Drive**

**Milledgeville, GA 31061, USA**

T: +1 (478) 452 0015

F: +1 (478) 452 0070

#### **100 Commerce Drive, Suite 303,**

**Newark, DE 19713, USA**

T: +1 (302) 294 44 46

F: +1 (302) 294 44 51

### HUNGARY

#### **RATH HUNGARIA KFT.**

**Porcelán utca 1**

**H-1106 Budapest**

T: +36 (1) 433 00 40

F: +36 (1) 261 90 52

### CZECH REPUBLIC

#### **RATH ŽÁROTECHNIKA SPOL. S.R.O.**

**Vorlesská 290**

**CZ-544 01 Dvůr Králové n. L.**

T: +420 (499) 32 15 77

F: +420 (499) 32 10 03

### MEXICO

#### **RATH GROUP S. DE RL. DE C.V.**

**Poniente 1, 206**

**64103, Monterrey**

**Nuevo Leon, Mexico**

T: +52 (1) 81 26760477

### POLAND

#### **RATH POLSKA SP. Z O.O.**

**ul. Budowlanych 11**

**PL-41 303 Dąbrowa Górnicza**

T: +48 (32) 268 47 01

F: +48 (32) 268 47 02

### UKRAINE

#### **RATH UKRAINA GmbH**

**ul. Schevchenko 37**

**UA-49044 Dnepr**

T: +380 (56) 785 30 35

F: +380 (56) 368 98 98

All information displayed here is just for your orientation and is not legally or technically binding. All property figures presented are not valid for calculation of industrial facilities. Any decisions based on the displayed information is the responsibility of the decision maker. The rights to changes and misprints are reserved.

